

HYUNDAI
POWER PRODUCTS

**PETROL SHREDDER
HBT75-3**

ORIGINAL INSTRUCTIONS

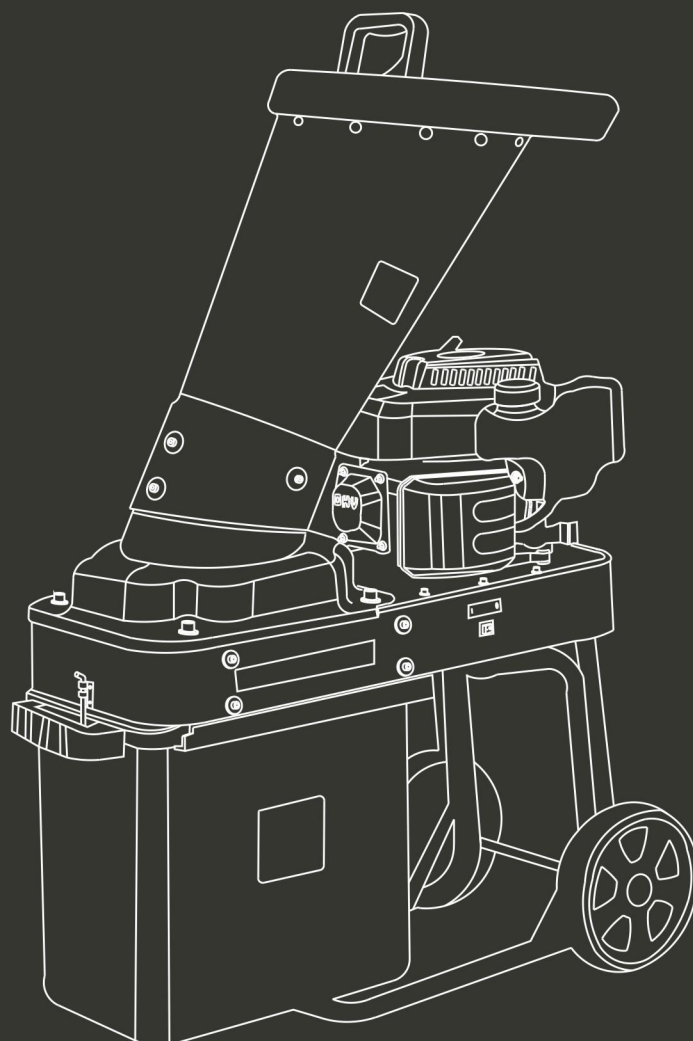

WARNING: Read thoroughly the instruction manual before use.

GENERAL SAFETY RULES



Warning symbol



Caution: Read carefully the manual before use.



Danger - Rotating blades. Keep hands and feet out of openings while machine is running



Keep bystanders away



Wear eye and ear protection



Do not use as a step



Wear protective gloves



Wear safety footwear



Danger – risk of fire



Caution – hot surface



Warning – exhaust gas. Do not inhale them



Guarantee sound power level

IMPORTANT

READ CAREFULLY BEFORE USE

KEEP FOR FUTURE REFERENCE

Training

Become familiar with the owner's manual before attempting to operate this equipment.

Preparation

- 1) Do not allow children to operate this equipment;
- 2) Do not operate this equipment in the vicinity of bystanders;
- 3) Do not run engine powered machines in an enclosed area since the exhaust from an engine contains carbon monoxide, which is colourless, odourless, and tasteless; carbon monoxide can be extremely dangerous in enclosed areas;
- 4) Wear ear protection and safety glasses at all times while operating the machine;
- 5) Avoid wearing clothing that is loose fitting or that has hanging cords or ties;
- 6) Only operate the machine in open space (e.g. not close to a wall or other fixed object) and on a firm, level surface;
- 7) Do not operate the machine on a paved or gravel surface where ejected material could cause injury;
- 8) Before starting the machine, check that all screws, nuts, bolts, and other fasteners are properly secured and that guards and screens are in place. Replace damaged or unreadable labels;
- 9) Use extra care in handling fuels. They are flammable and the vapours are explosive. The following points should be observed:
 - use only an approved container;
 - Never remove the fuel cap or add fuel with the power source running. Allow engine and exhaust components to cool before refuelling;
 - do not smoke;
 - never refuel the machine indoors;
 - never store the machine or fuel container inside where there is an open flame, such as a water heater;
 - if fuel is spilled, do not attempt to start the power source, but move the machine away from the area of spillage before starting;
 - always replace and securely tighten the fuel cap after refuelling;
 - if the fuel tank is drained, this should be done outdoors.

Operation

- 1) Before starting the machine, look into the feeding chamber to make certain that it is empty;
- 2) Keep your face and body away from the feed intake opening;
- 3) Do not allow hands or any other part of the body or clothing inside the feeding chamber, discharge chute, or near any moving part;

- 4) Keep proper balance and footing at all times. Do not overreach. Never stand at a higher level than the base of the machine when feeding material into it;
- 5) Always stand clear of the discharge zone when operating this machine;
- 6) When feeding material into the machine be extremely careful that pieces of metal, rocks, bottles, cans or other foreign objects are not included;
- 7) If the cutting mechanism strikes any foreign objects or if the machine should start making any unusual noise or vibration, shut off the power source and allow the machine to stop. Disconnect the spark plug wire from the spark plug (electric unit disconnect from supply) and take the following steps:
 - Inspect for damage;
 - Check for and tighten any loose parts ;
 - Have any damaged parts replaced or repaired with parts having equivalent specifications.
- 8) Do not allow processed material to build up in the discharge zone; this may prevent proper discharge and can result in kickback of material through the feed intake opening;
- 9) If the machine becomes clogged at the inlet opening or discharge chute shut-off the power source and disconnect the spark plug wire or remove the ignition key before clearing debris in the inlet opening or discharge chute. Keep the power source clear of debris and other accumulations to prevent damage to the power source or possible fire. Remember that operating the starting mechanism on engine powered machines will still cause the cutting means to move;
- 10) keep all guards and deflectors in place and in good working condition;
- 11) Do not tamper with the power source governor settings; the governor controls the safe maximum operating speed and protects the power source and all moving parts from damage caused by over-speed. Seek authorised service if a problem exists;
- 12) Do not transport this machine while the power source is running;
- 13) Shut off the power source and disconnect the spark plug lead (electric unit disconnect from supply) whenever you leave the work area;
- 14) Do not tilt the machine while the power source is running.

Maintenance and storage

- a) When the machine is stopped for servicing, inspection, or storage, or to change an accessory, shut off the power source, disconnect the spark plug wire from the spark plug (electric unit disconnect from supply), make sure that all moving parts have come to a complete stop and, where a key is fitted remove the key. Allow the machine to cool before making any inspections, adjustments, etc.
- b) Store the machine where fuel vapour will not reach an open flame or spark. For extended storage periods, run the unit dry of fuel. Always allow the machine to cool before storing;
- c) When servicing the cutting means be aware that, even though the power source will not start due to the interlock feature of the guard, the cutting means can still be moved by a manual starting mechanism.

Additional safety instructions for units with bagging attachments

- a) Shut-off the power unit before attaching or removing the bag.

INTENDED USE

This shredder is intended for mulching garden and pruning waste such as green branches, twigs, brush, vines, and long grasses. DO NOT use this shredder for chipping construction debris, plastic, paper products, rope or twine, or any material that may contain metal.

GENERAL IDENTIFICATION

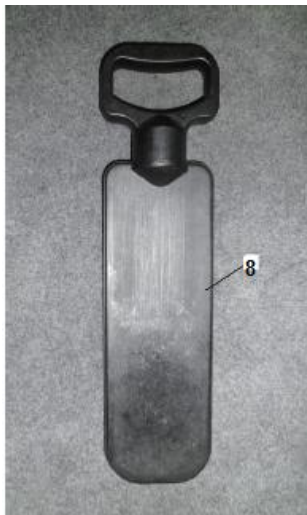

- 1. Tipper
- 2. Discharge chute
- 3. Trash can
- 4. Starter cable

- 5. Motor
- 6. Switch
- 7. Wheel
- 8. Pusher

ASSEMBLY INSTRUCTIONS

Hopper installation

1. Carefully insert the hopper into the hopper holder (Fig. A)
2. Locate the screws (total 4 screws) to correct position.
3. Fasten the screw completely.

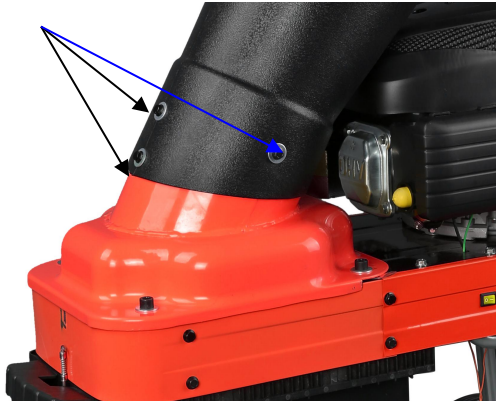

Fig A

Dustbin installation

1. Install the handle on the dustbin (on the side without the key) and screw it into place.



2. Install the two metal bars inside the bin by inserting the screws through the holes (on the 3 sides of the bin). Secure them with the nuts. Fix then the two bars together.



3. Insert the dustbin into body (Fig B), make sure the key well connected with transverter. (Fig C)
4. Use the safe key to lock the dustbin well. (Fig D)

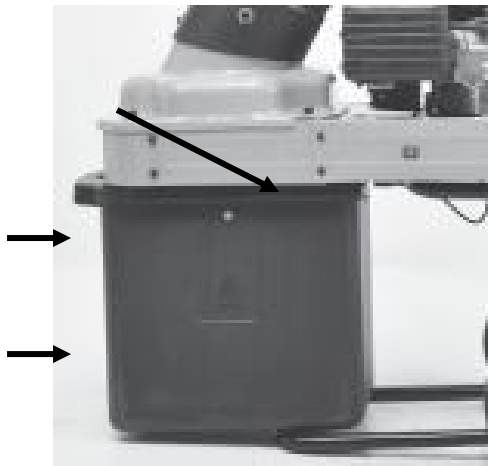

Fig B



Fig D

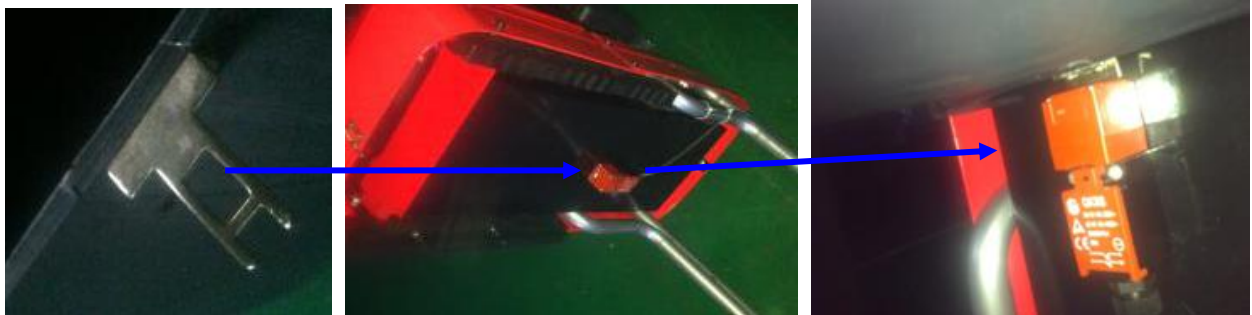

Fig C

Wheel installation

Place the wheels on both sides at the bottom of the machine. Secure them with a bolt and a flat washer. Then place the decoration frame.



OIL AND FUEL FILLING

WARNING! Engine delivered without oil or fuel: Fill up with gasoline and oil before starting the engine:

1) Fuel

Recommended fuel: unleaded petrol with an octane rating of at least 87.

Open the fuel tank cap. Pour the fuel carefully into the tank without overflowing. Never exceed the maximum level. Then close the tank with its cap.

Wipe off any fuel that may have spilled.

WARNING ! Petrol is extremely flammable.

Store fuel in cans specifically designed for this.

Fill the fuel tank only outdoors and before starting the engine. Do not smoke when filling the fuel tank or handling fuel.

Never open the fuel tank cap and never add fuel when the engine is running or when it is hot. If fuel has spilled, do not start the engine, move the tool away from where the fuel was spilled, and take care not to create a spark or flame until the fuel vapors have dissipated.

Close all fuel tank and canister caps completely.

Before tilting the mower to service the blade or drain the oil, empty the fuel tank.

WARNING: Never fill the fuel tank indoors, when the engine is running or before the engine has been able to cool for at least 15 minutes after use.

CAUTION: Do not use unapproved gasoline, such as E15 and E85. Do not mix oil with gasoline or modify the engine to run on alternative fuels. Using unapproved fuels will damage engine parts and void the engine warranty.

To protect the fuel system from scale build-up, add a fuel stabilizer to the fuel.

2) Oil

Recommended oil: SAE 15W-40 4-stroke oil, 0.5L.

Open the oil tank cap. Pour the oil into the tank to the limit. Never exceed the tank limit. Then close the tank with the cap.

Wipe off any overflow.

Oil level check

- Check the oil level after the engine has stopped.
- Remove the plug / dipstick from the oil tank and wipe it off.
- Insert the oil tank cap / dipstick into the tank neck without screwing it back, then remove it to check the oil level.
- If the oil level is close to or below the lower limit of the dipstick, remove the cap / dipstick and fill the recommended oil tank to the upper limit of the dipstick (lower edge of the neck). Do not overfill.
- Replace the oil tank cap / dipstick

STARTING THE ENGINE

- Turn engine switch to ON position.(Fig F)
- Press the primer button 3 times. (Fig G)
- Pull the recoil starter handle gently until it engages the give it a good strong pull to start the engine. (Fig H)

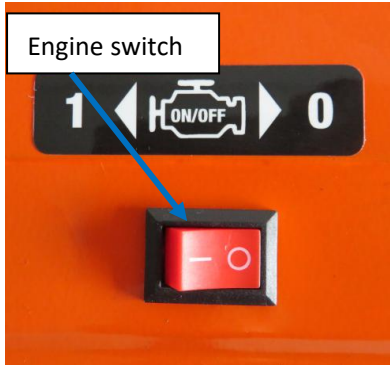

Fig F



Fig G



Fig H

TURN THE ENGINE OFF

Turn the engine switch on OFF position, or take out the dustbin.

OPERATIONS

WARNING! Never operate without dustbin; it may be dangerous to your body.

1. TOP HOPPER-FRONT CUT

The large sloping front chute of the top hopper is designed to accept leaves and small garden clippings. Shredding and mulching is achieved by natural suction of the debris through the blade chamber. Do not overfeed and do not feed wet, soggy material into the shredder as this may clog the blade chamber and the discharge chute. (Fig I)



Fig I

2. TOP HOPPER-BACK CHUTE

The smaller back chute of the top Hopper accepts medium to larger size garden clippings. Shredding and mulching is achieved through the same action as the front chute. If finer type mulch is required, re-feed the mulch through again until the desired result is obtained. (Fig J)



Fig J

3. MATERIAL PUSH STICK

User supplied push stick to push remaining material into hopper opening. **DO NOT USE HANDS.** (Fig K)



Fig K

MAINTENANCE



WARNING! Priors to any maintenance, to stop engine and switch if off first.



WARNING! Disconnect spark plug wire from the spark plug to prevent unintentional engine starting.



WARNING! Unintentional sparking can result in fire.



WARNING! Unintentional start-up can result in entanglement, traumatic amputation, or laceration.



CAUTION: Use only genuine replacement engine parts. None compliant parts may damage the engine, and may result in injury. In addition, use of other parts may void your warranty rights.

Regular maintenance will improve the performance and extend the life of the engine. Please follow the instructions and schedules indicated below:

Task	Perform task at hourly or calendar interval, whichever comes first	Each Use	25 Hours or Every Season	50 Hours or Every Season	100 Hours or Every Season	100-300 Hours
Check Oil Level		•				
Change Oil				• ★		
Clean Air Cleaner			• ★★			
Check Flywheel Brake Pad				•		
Check-clean Spark Plug					•	
Check-adjust idle speed						•
Clean Combustion Chamber						•
Check Fuel Line	Every 2 years (Replace if necessary)					

- ★ Drain engine oil and change it after first 5-8 hours of operation and every 50 hours or three months after that. It is also a highly recommendation to change oil every 25 hours.
- ★ Clean air cleaner more frequently when working under dusty conditions or when airborne debris is present. Replace of air cleaner element if it is very dirty.

BLADE MAINTENANCE



WARNING! Before removing Top Hopper screw, ensure the machine is switched off, and the machine is completely stopped.



WARNING! Take extreme care not to come in contact with cutting blades. Danger!



WARNING! If ejection chute becomes clogged or cutting blades become jammed, under no circumstances should you place your hands in ejection chute to try to clear obstruction, as this will lead to serious injury.

1. Switch the machine off, and make sure the machine is completely stopped.
2. Wear gloves when attempting any maintenance to the cutting blades.
3. Loosen four safety screws as shown on (Fig L), carefully lift up the hopper.
4. Steps on the hopper support with the foot, takes a tool to be fixed the blade of plate. (Fig M)
5. Dismantles bit anchor screw (Fig N) with the suitable tool.
6. Close the hopper, tighten the screws.

NOTE: The blade is double edged. Should you have to change the blade, rotate the blade 180 degree for sharper edge.

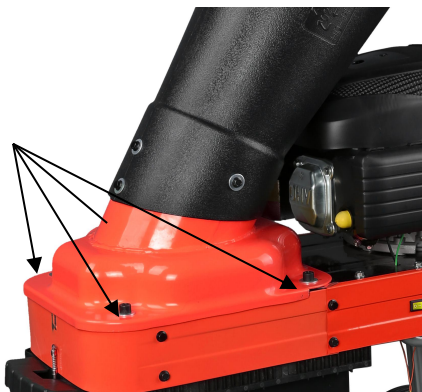

Fig L



Fig M

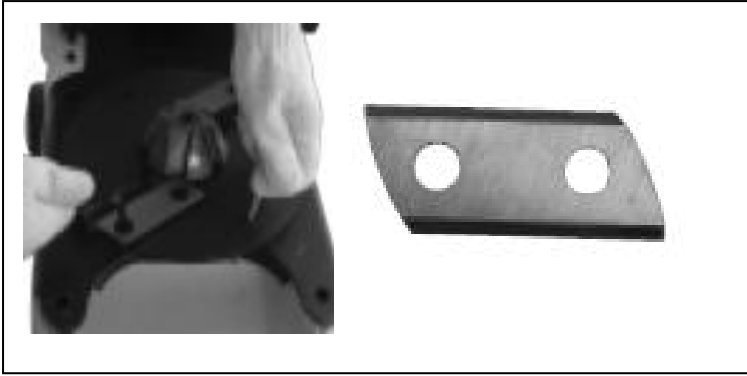

Fig N

DRAINING THE OIL

1. Leave the engine running until the fuel runs out and wait for the engine to stop and cool down slightly.
2. Disconnect the spark plug.
3. Remove the oil drain plug (A). Empty the oil into a suitable container. (Fig. O)
4. Clean the oil drain plug before reinstalling it.
5. Add oil as explained in the "oil and fuel filling" section.



WARNING! Prevent skin contact with used engine oil. Wash your skin with soap and water after oil change.



CAUTION: Used oil is a hazardous waste product. It is suggested to bring used oil to your local recycling center with properly sealed container a sealed container to your local recycling center. Don not discard with household waste.



Fig O

AIR CLEANER MAINTENANCE

A dirty air filter will increase air intake restriction. Periodical maintenance of air filter will help to improve engine performance and reduce emissions.



WARNING! Never clean air filter with gasoline or an easy ignited solvent it may cause explosion.

1. Remove the air cleaner cover (A), and carefully remove the filter element (B) (Fig P)
2. Clean all parts.
3. Blow off dirt from filter element with pressure air.
4. Reinstall the filter element and air cleaner cover.

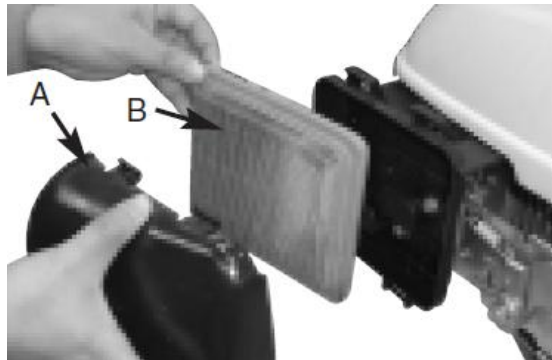

Fig P

SPARK PLUG

Recommended spark plug: **F7RTC**.

Stop the engine and allow it to cool



WARNING! DO NOT use an incorrectly rated plug. It is essential to keep the spark plug in good condition-clean and properly adjusted.



WARNING! To keep engine at top performance spark plug gap should be within specified and carbon built up free.

1. Removing spark plug with a spark plug wrench.
2. Inspect the spark plug visually. If spark plug is worn, dirty or has cracks, replace with the recommended type and heat range.
3. The correct air gap is 0.70 to 0.80mm (Fig Q)
4. Tighten the spark plug.
5. After spark plug is tight; torque to 25-30N.m.

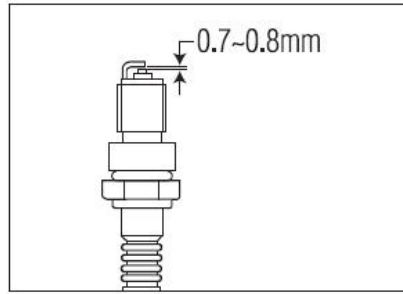

Fig Q



WARNING! An incorrectly tightened spark plug may result in poor engine performance and permanent engine damage.

COMBUSTION DEPOSITS

We recommend that you should remove combustion deposits from the cylinder head, top of piston, and around valves after every 100-300 hours of usage.

MUFFLER

WARNING! If engine just running down, do not touch muffler. Allow it to cool before operation.

TRANSPORTING AND STORAGE

When storing engine for more than 30 days.

1. Store in a dry and clean area.
2. Run engine until fuel tank is empty and engine stops or add gasoline preservative and running engine after adding for several minutes.

WARNING! Gasoline is flammable. Fuel or fuel vapors may explode. Keep sparks and open flames from the working area.

3. Change engine lubrication oil.
4. Clean the exterior surfaces of the engine.
5. Remove spark plug, pour one teaspoon of fresh engine oil into cylinder.
Re-install spark plug without the spark plug wire attached. Pull starter rope slowly several times to distribute the oil in the engine.
6. Slowly pull start handle (A) until the resistance is reached, then stop pulling.
At that point, valves are closed, that will prevent dust and rust from entering cylinder. (Fig R)
7. Cover engine well to prevent dust.

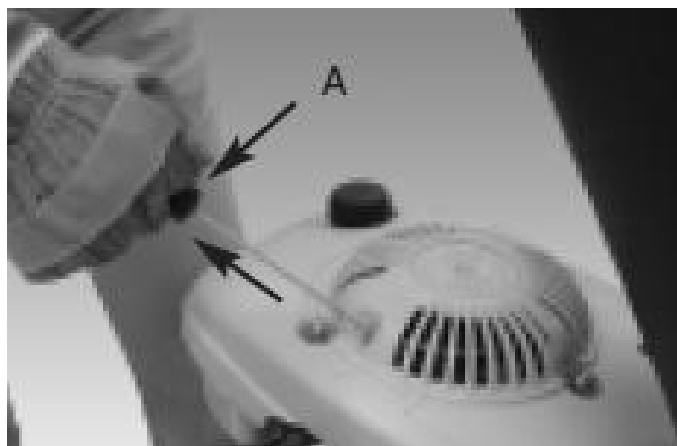

Fig R



WARNING! When you service the engine, inspect the blade, or clean the underside of the housing, make sure to always tip the engine with spark plug up. Transporting or tipping the engine with the spark plug down will cause:

1. Engine smoking
2. Hard starting
3. Spark plug fouling
4. Oil or petrol saturation of the air filter

Technical data

Sound pressure level: 106 dB(A) K=3dB(A)

Sound power level: 110 dB(A) K=3dB(A)

Guarantee sound power level: 113 dB(A)

Power: 3,1 kW

Weight: 34,5 kg

Speed: 3000/min

Engine displacement: 174 cm³

Cutting diameter: 44mm

Cutting width: 225 mm

Oil volume: 500 ml

Fuel tank volume: 1000 ml

The noise emission is measured according the requirements of the standards EN13683 Annex F.

CE DECLARATION



BUILDER SAS
32, rue Aristide Bergès - ZI 31270 Cugnaux - France

Declare that the following tool:

Petrol Shredder

HBT75-3

Serial number: 20211159200-20211159349

Is in conformity with the requirements of the **Directive Machine 2006/42/EC** and to the followings Europeans

Directives:

EMC Directive 2014/30/EU

ROHS Directive 2015/865/EU amending 2011/65/EU

Emission directive (EU) 2016/1628

Noise Directive 2000/14/EC and 2005/88/EC Annex X

This tool is also in conformity with the following these standards:

EN 13683:2003+A2:2011, EN ISO 14982:2009

Sound power level: 110 dB(A) K=3dB(A)

Guarantee sound power level: 113 dB(A)

Responsible of the technical file: Julia Zou

Cugnaux, 19/08/2021

Philippe MARIE / PDG

HYUNDAI

WARRANTY

The manufacturer guarantees the product against defects in material and workmanship for a period of 2 years from the date of the original purchase. The warranty only applies if the product is for household use. The warranty does not cover breakdowns due to normal wear and tear.

The manufacturer agrees to replace parts identified as defective by the designated distributor. The manufacturer does not accept responsibility for the replacement of the machine, in whole or in part, and/or ensuing damage.

The warranty does not cover breakdowns due to:

- insufficient maintenance.
- abnormal assembly, adjustment or operations of the product.
- parts subject to normal wear and tear.

The warranty does not extend to:

- shipping and packaging costs.
- using the tool for a purpose other than that for which it was designed.
- the use and maintenance of the machine done in a manner not described in the user manual.

Due to our policy of continuous product improvement, we reserve the right to alter or change specifications without notice. Consequently, the product may be different from the information contained therein, but a modification will be undertaken without notice if it is recognized as an improvement of the preceding characteristic.

READ THE MANUAL CAREFULLY BEFORE USING THE MACHINE.

When ordering spare parts, please indicate the part number or code, you can find this in the spare parts list in this manual. Keep the purchase receipt; without it, the warranty is invalid. To help you with your product, we invite you to contact us by phone or via our website:

- **+33 (0)9.70.75.30.30**
- **<https://services.swap-europe.com/contact>**

You must create a "ticket" via the web platform.

- Register or create your account.
- Indicate the reference of the tool.
- Choose the subject of your request.
- Describe your problem.
- Attach these files: invoice or sales receipt, photo of the identification plate (serial number), photo of the part you need (for example: pins on the transformer plug which are broken).



PRODUCT FAILURE

WHAT TO DO IF MY MACHINE BREAKS DOWN?

If you bought your product in a store:

- a) Empty the fuel tank.
- b) Make sure that your machine is complete with all accessories supplied, and clean! If this is not the case, the repairer will refuse the machine.

Go to the store with the complete machine and with the receipt or invoice.

If you bought your product on a website:

- a) Empty the fuel tank.
- b) Make sure that your machine is complete with all accessories supplied, and clean! If this is not the case, the repairer will refuse the machine.
- c) Create a SWAP-Europe service ticket on the site: <https://services.swap-europe.com> When making the request on SWAP-Europe, you must attach the invoice and the photo of the nameplate (serial number).
- d) Contact the repair station to make sure it is available before dropping off the machine.

Go to the repair station with the complete machine packed, accompanied by the purchase invoice and the station support sheet downloadable after the service request is completed on the SWAP-Europe site

For machines with engine failure from manufacturers BRIGGS & STRATTON, HONDA and RATO, please refer to the following instructions.

Repairs will be done by approved engine manufacturers of these manufacturers, see their site:

- <http://www.briggsandstratton.com/eu/fr>
- <http://www.honda-engines-eu.com/fr/service-network-page;jsessionid=5EE8456CF39CD572AA2AEEDFD290CDAE>
- <https://www.rato-europe.com/it/service-network>

Please keep your original packaging to allow for after-sales service returns or pack your machine with a similar cardboard box of the same dimensions.

For any question concerning our after-sales service you can make a request on our website <https://services.swap-europe.com>

Our hotline remains available at +33 (9) 70 75 30 30.



WARRANTY EXCLUSIONS

THE WARRANTY DOES NOT COVER:

- Start-up and setting up of the product.
- Damage resulting from normal wear and tear of the product.
- Damage resulting from improper use of the product.
- Damage resulting from assembly or start-up not in accordance with the user manual.
- Breakdowns related to carburetion beyond 90 days and fouling of carburetors.
- Periodic and standard maintenance events.
- Actions of modification and dismantling that directly void the warranty.
- Products whose original authentication marking (brand, serial number) has been degraded, altered or withdrawn.
- Replacement of consumables.
- The use of non-original parts.
- Breakage of parts following impacts or projections.
- Accessories breakdowns.
- Defects and their consequences linked to any external cause.
- Loss of components and loss due to insufficient screwing.
- Cutting components and any damage related to the loosening of parts.
- Overload or overheating.
- Poor power supply quality: faulty voltage, voltage error, etc.
- Damages resulting from the deprivation of enjoyment of the product during the time necessary for repairs and more generally the costs related to the immobilization of the product.
- The costs of a second opinion established by a third party following an estimate by a SWAP-Europe repair station
- The use of a product which would show a defect or a breakage which was not the subject of an immediate report and/or repair with the services of SWAP-Europe.
- Deterioration linked to transport and storage*.
- Launchers beyond 90 days.
- Oil, petrol, grease.
- Damages related to the use of non-compliant fuels or lubricants.

* In accordance with transport legislation, damage related to transport must be declared to carriers within 48 hours maximum after observation by registered letter with acknowledgement of receipt.

This document is a supplement to your notice, a non-exhaustive list.

Attention: all orders must be checked in the presence of the delivery person. In case of refusal by the delivery person, it you must simply refuse the delivery and notify your refusal.

Reminder: the reserves do not exclude the notification by registered letter with acknowledgement within 72 hours.

Information:

Thermal devices must be wintered each season (service available on the SWAP-Europe site). Batteries must be charged before being stored.

HYUNDAI
POWER PRODUCTS

For Inquiries, please contact:

BUILDER SAS
32, Rue Aristide Bergès Z1 31270 Cugnaux, France
Tél.: +33(0)5.34.502.502 Fax : +33(0)5.34.502.503
<http://www.hyundaipower-fr.com/>
Fabriqué en République Populaire de Chine(PRC)